

# Series 5400

- ▶ Heavy-duty valve design actuator closes on centerline
- ▶ No packing to maintain, ever
- ▶ Accurate, repeatable control
- ▶ Ideal for corrosive and abrasive slurries
- ▶ True feedback positioning



Red Valve's Series 5400 Control Pinch Valve features centerline valve closure, true feedback positioning, compact size, enclosed mechanical parts and accurate, repeatable variable venturi flow control.

Centerline closure is extremely important for larger size pinch on abrasive and high velocity applications. Centerline closure outlasts all other types of gate, plug or ball valves on control of abrasive and corrosive slurries. The resilient elastomer sleeve outlasts even stellite-coated control valves.

Cone Sleeves can be specified to further enhance control performance and match the exact  $C_v$  level desired. True feedback positioning is accomplished through the direct linkage of the pneumatic positioner to the valve stem shaft. The benefits of true feedback positioning on Red Valve Series 5400s include accurate small responsive signal changes to the positioner, causing similar changes in true valve position, greatly enhancing control accuracy and repeatability.

## Materials of Construction

- ▶ Ductile iron body
- ▶ Sleeves available in Pure Gum Rubber, Neoprene, Hypalon®, Chlorobutyl, Buna-N, EPDM and Viton®
- ▶ ATO/ATC, ATO/Fail Close, ATC/Fail Open hydraulic or electric actuators
- ▶ Drilled and tapped to mate with ANSI B16.5 Class 150 flanges

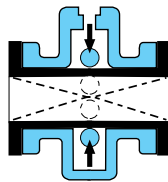

Closing Action

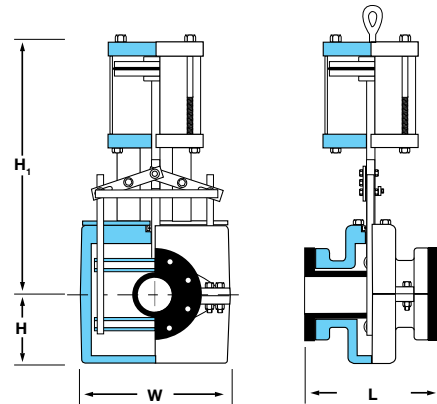

## Dimensions Series 5400

VALVE SIZE	LENGTH L	WIDTH W	HEIGHT		WORKING PRESSURE psi**	WEIGHT ATO/ATC lbs*
			H	ATO/ATC H <sub>1</sub> *		
4"	9"	10-1/2"	5-3/4"	26-1/2"	150	210
5"	10"	15-3/8"	8-1/2"	32"	150	250
6"	10-1/2"	18-1/4"	7-7/8"	32-1/8"	150	288
8"	16"	23-1/4"	9-1/8"	32-1/2"	150	385
10"	20"	29-3/4"	10-1/2"	43"	150	520
12"	24"	35"	11-1/2"	46"	150	709
14"	28"	37-1/2"	14-1/2"	51-3/4"	150	1,200
16"	32"	41-1/2"	15-1/2"	56-1/2"	150	1,600
18"	36"	51"	17"	59-1/2"	150	2,000
20"	40"	47-3/4"	17-3/4"	62-3/4"	150	2,450
24"	48"	57"	25-1/2"	***69"	150	4,200
30"	60"	78"	20-1/2"	***74"	50	8,300
36"	72"	77"	32"	***96"	45	14,300

\*Consult factory for specific heights and weights of Fail-Close or Fail-Open valves.

\*\*Higher working pressures available.

\*\*\*Hydraulic or electric only.

For larger sizes up to 72", consult factory.